

TAKSAN RADYAL MATKAP

4.5. DIŐLI ŐEMASI:

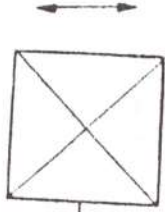

Matkap motoru
 $n = 715/1425 \text{ dev./dak.}$
 $N = 2,3/3,7 \text{ KW.}$

1 Sürtünme halkası
2 Hız saati
3 Yağ pompası

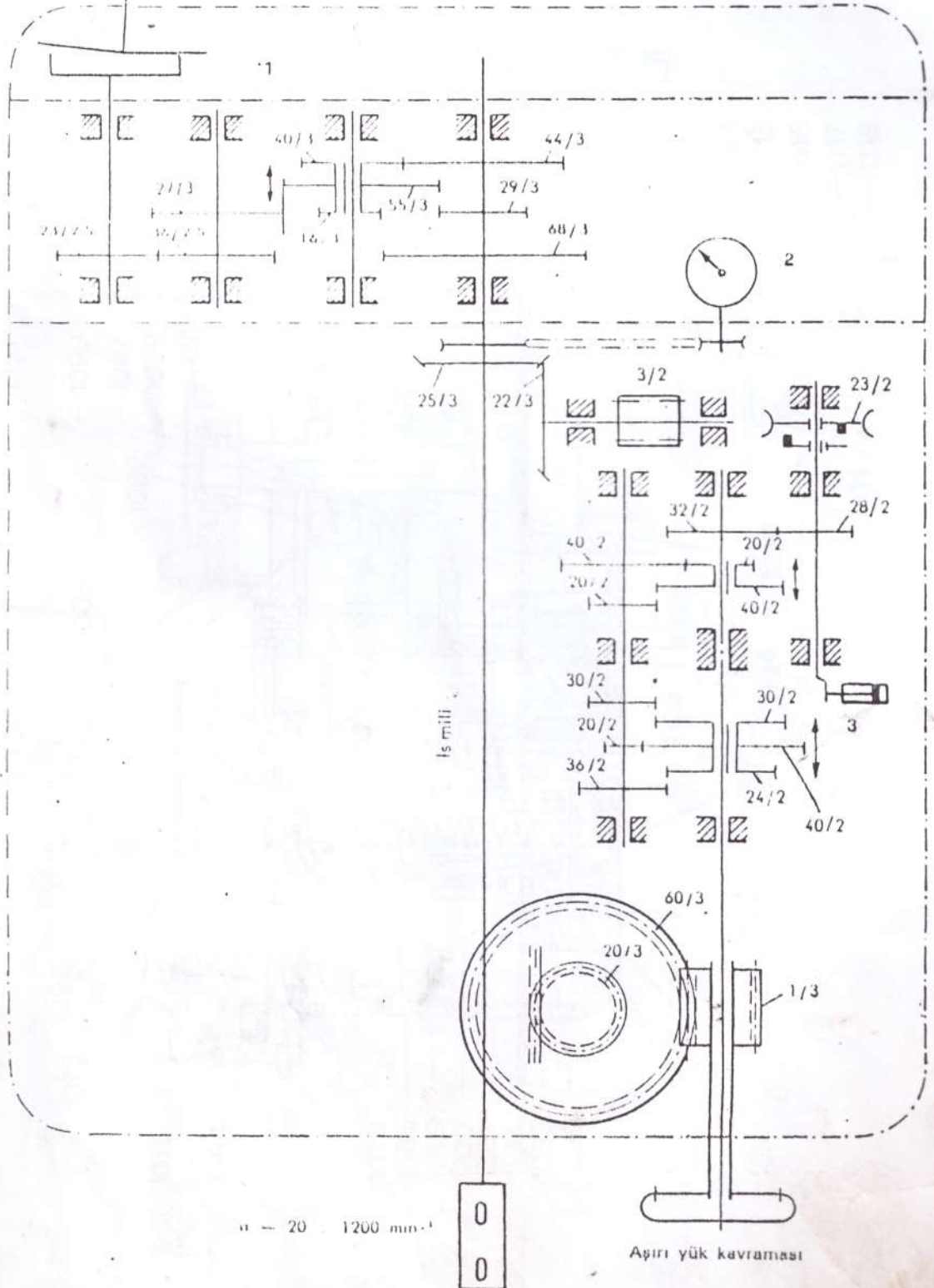

5/3 Tahrik Ünitesi

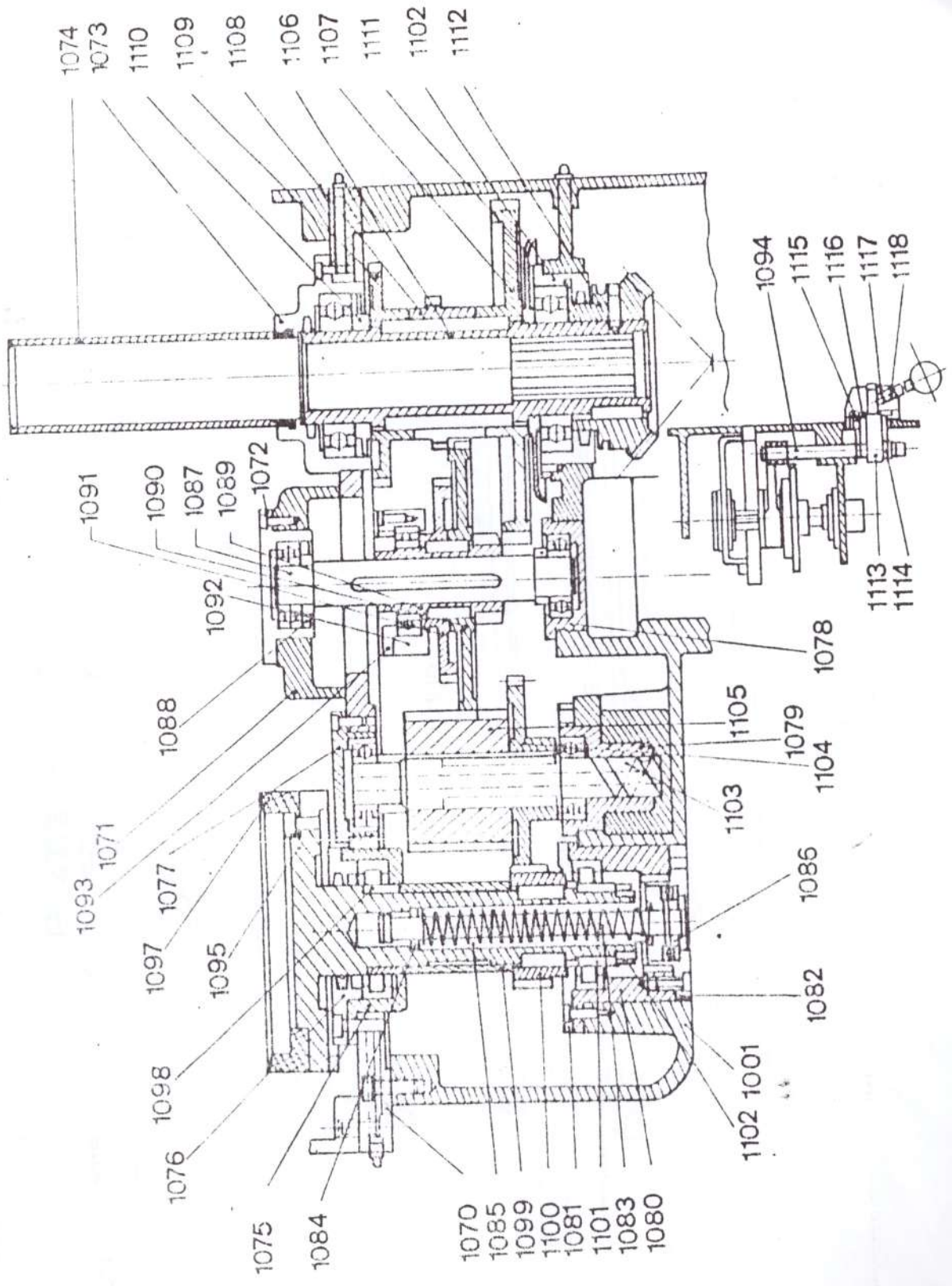

5/2 Delme mili ve ilerleme dişleri

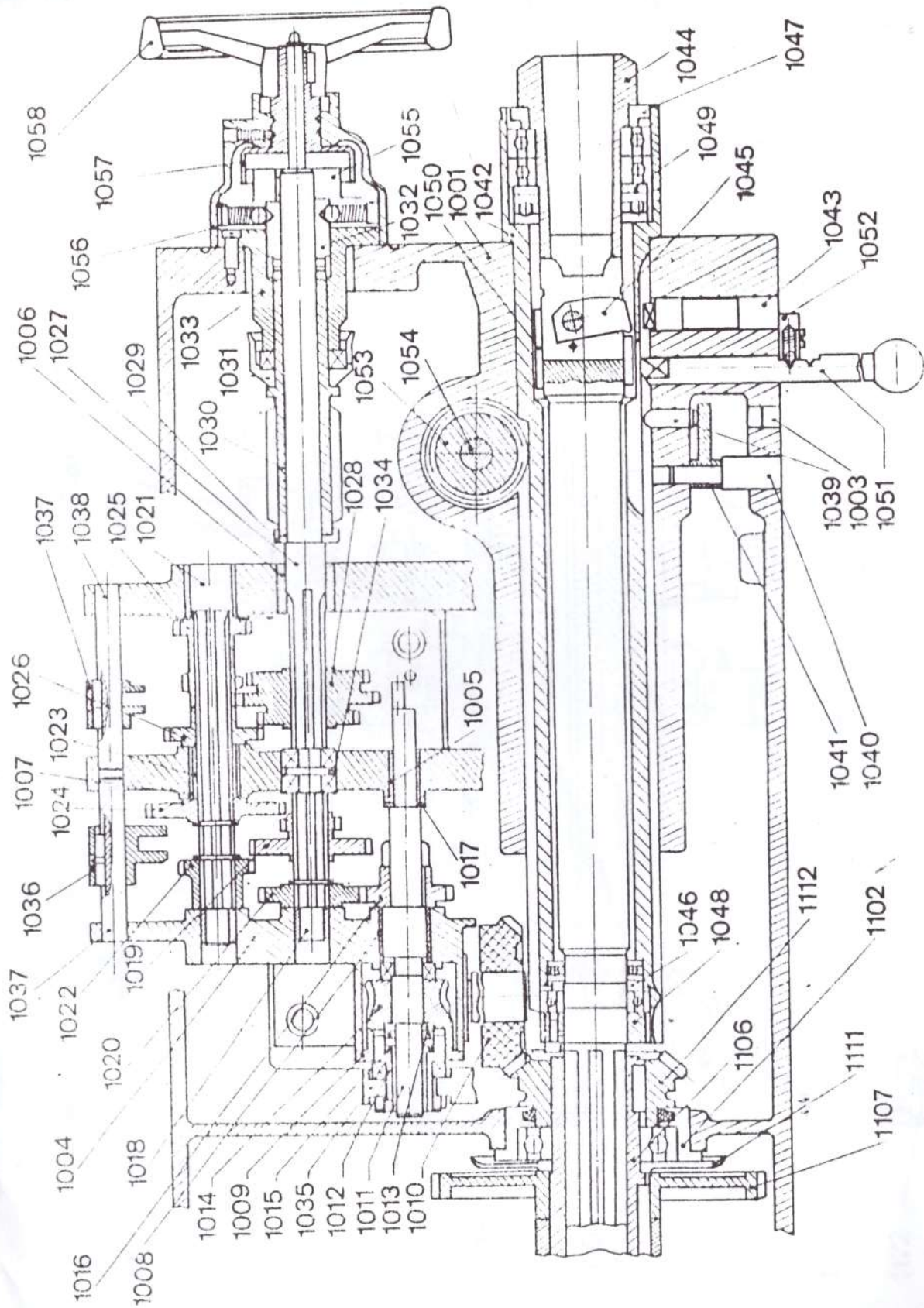

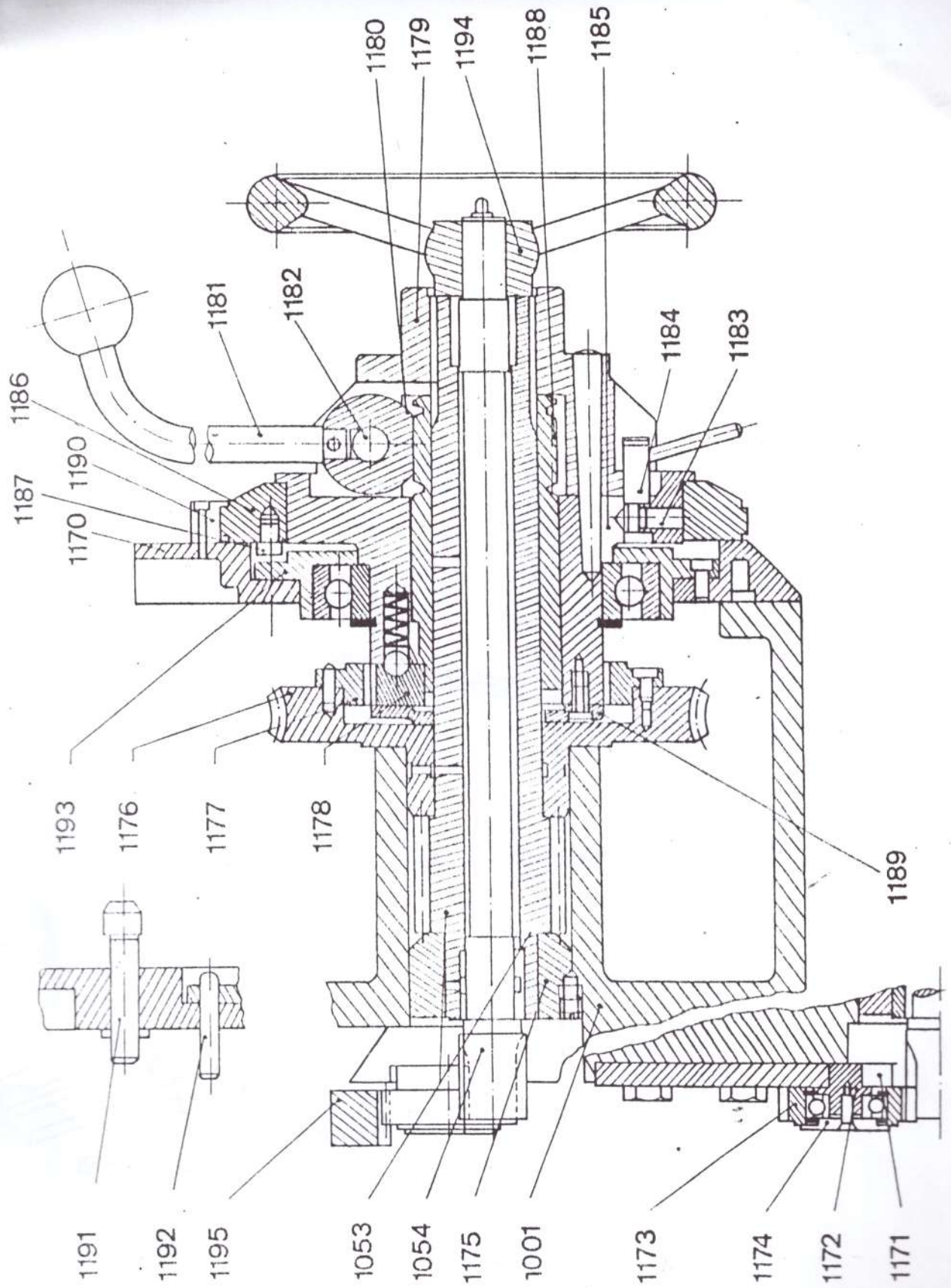

5/7 Kilitleme mekanizması

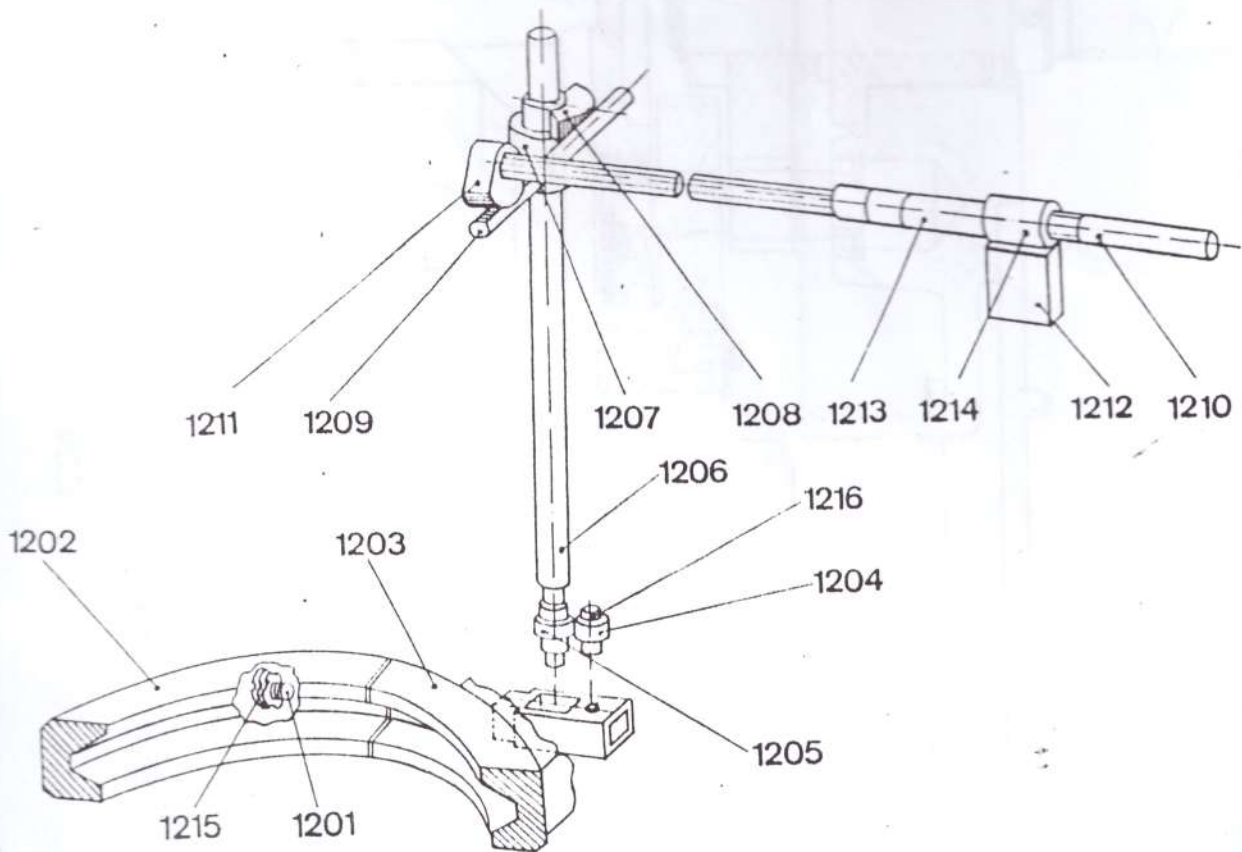

5/8 Düşey hareket dişli sistemi

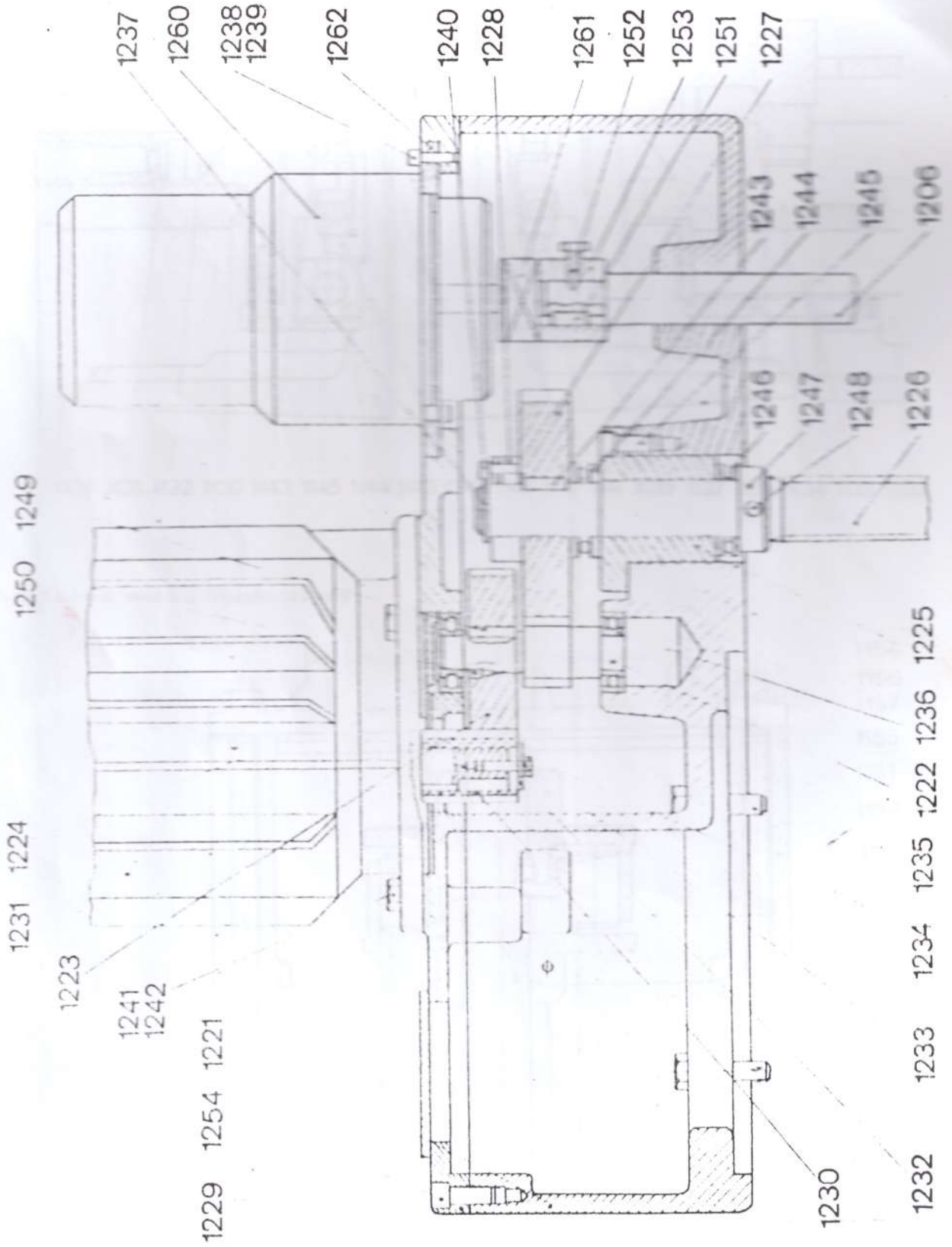

5/4 Üst kızak

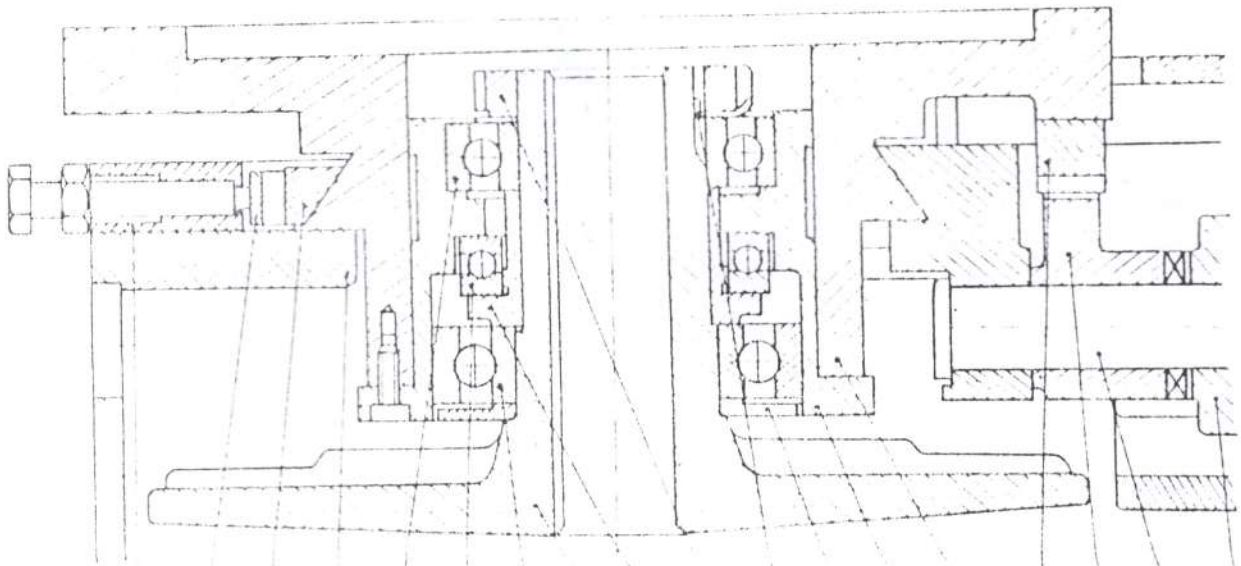

1136 1131 1132 1130 1143 1145 1144 1142 1140 1146 1147 1141 1139 1137 1138 1134 1133 1135

5/5 Elektrik motoru akuple sistemi

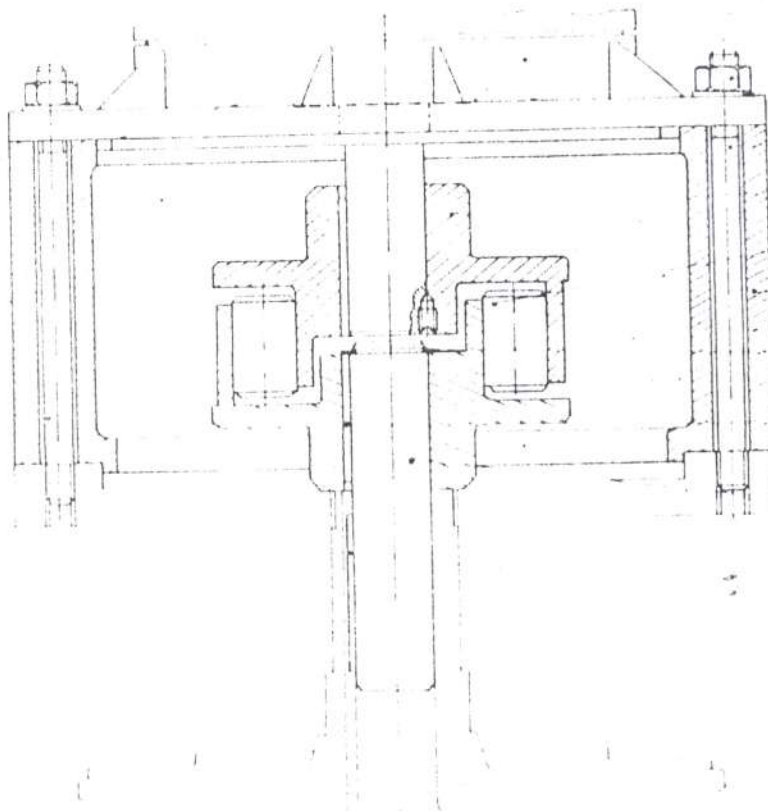

1154
1156
1157
1155
1151
1158
1153
1159
1160
1152
1161